



# Ratchet flywheel regenerative system to enhance energy captured for electric vehicle

Cite as: AIP Conference Proceedings **2187**, 020040 (2019); <https://doi.org/10.1063/1.5138295>  
Published Online: 10 December 2019

Agung Prijo Budijono, I. Nyoman Sutantra, and Agus Sigit Pramono



View Online



Export Citation

## Lock-in Amplifiers up to 600 MHz



Zurich  
Instruments



# Ratchet Flywheel Regenerative System to Enhance Energy Captured for Electric Vehicle

Agung Prijo Budijono <sup>a)</sup>, I Nyoman Sutantra <sup>b)</sup>, and Agus Sigit Pramono <sup>c)</sup>

*Institute Teknologi Sepuluh Nopember Surabaya (ITS) Mechanical Engineering Department, Indonesia*

<sup>a)</sup>Corresponding author: agungprijobudijono@gmail.com

<sup>b)</sup> tantra@me.its.ac.id

<sup>c)</sup> pramono@me.its.ac.id

**Abstract.** Regenerative Braking System (RBS) converts kinetic energy into electrical energy by using a motor and functions as a generator when decelerations occur. Regenerative braking is an effective alternative to increase the driving range of a vehicle and can save around 8% - 25% of the total energy used by a vehicle. The purpose of this research is to produce a design of the Ratchet Flywheel Regenerative System and its system topology. The design of this system is to optimize the download of vehicle kinetic energy based on the duration of energy transfer that occurs. This study focuses on the flywheel energy download system and is done by numerical simulation using MATLAB software. The method to be designed is to apply of ratchet flywheel topologies.

## INTRODUCTION

Electric vehicle provides maximum torque at low speeds, while ICE provides maximum torque at certain speeds. Until now, the weakness of the electric vehicle is the limit of electrical energy that can be used while driving. This weakness can be anticipated by the existence of system regenerative braking. Regenerative braking is an important technology for improving energy efficiency and driving distance on Electric Vehicles. The regenerative braking method has gained more popularity when used in Formula 1 (F1) vehicles. Electro-mechanical regenerative braking system (RBS) converts kinetic energy into electrical energy by using a motor and functions as a generator when decelerations occur. The results of the study show that up to 50% of total braking energy can be reused in urban driving cycles [5]. In a Regenerative braking design system, braking strategies and increased vehicle efficiency are very important. Almost all electric vehicles like the Prius, Leaf and S Model, are designed to be driven by axle motors, either regenerative brake or mechanical brake (conventional brake) designed to work serially or parallel [7]. The motor will provide braking torque to the wheels and braking in this way compared to conventional braking causing several effects, namely the presence of wheel lock and slip and pounding on the vehicle [6]. [5] shows the capture of Regenerative Braking energy with Downshift Transmission. The braking system uses a hydraulic braking system (HBS). Meanwhile, a thermoelectric generator converts heat from an engine system into electrical energy [1]. Furthermore, one of the important components for downloading energy in the regenerative braking system is Flywheel. According to [2,3] the flywheel energy storage system produces greater energy efficiency compared to lithium-ion batteries and energy consumption (energy released) decreases by 22.7%.

## METHODS

Energy that cannot be captured is caused by rolling resistance consumption, water resistance consumption, ramp consumption and heat consumption. Only components that rotate with large dimensions that contribute to analyze energy that can be reused. The following is a design of FRCS system

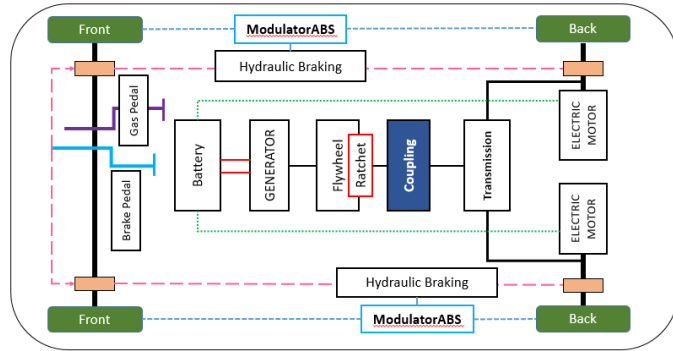

**FIGURE 1.** Ratchet Flywheel Regenerative System concept

From figure 1, topology of FRCS has been simplified to overview the design with laboratory scale.

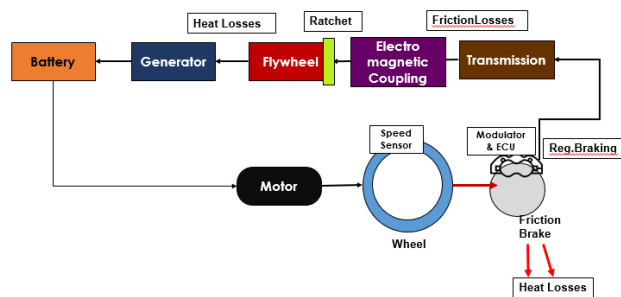

**FIGURE 2.** Illustration of simple FRCS concept

Figure 2 showed that the simplification of topology system from figure 1.

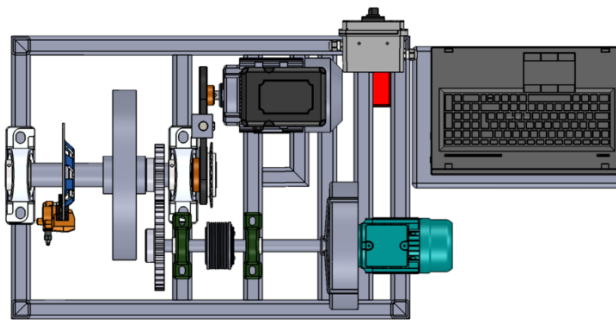

**FIGURE 3.** Illustration of simple FRCS with 3D parametric modeling

The components consist of: Battery, Electric motor, Braking system, *Flywheel (Big one)* as vehicle's wheel, electromagnetic coupling, *Flywheel (Medium one)* as flywheel for energy harvesting, Generator, *Tensioner, Gear to gear connection, Belt Connection*. The work flow diagram of FRCS can be shown at the picture below :

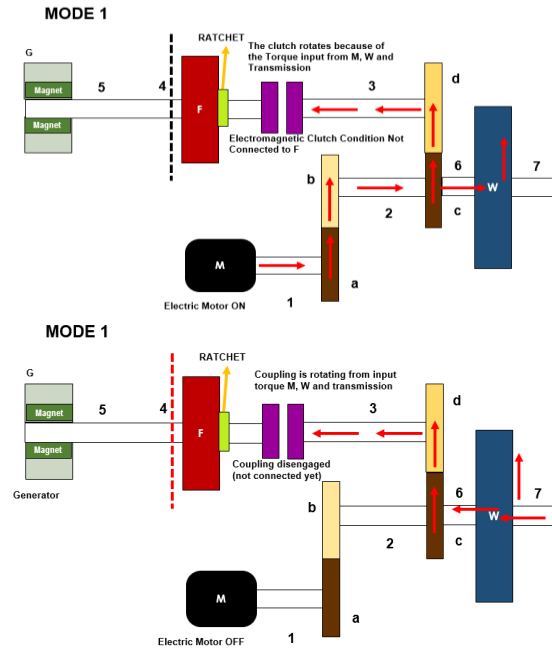

FIGURE 4. Workflow diagram of FRCS Mode 1

In mode 1 there are two events that take place, namely:

- When the vehicle starts running it will have a speed of  $V_{a1}$ . In a certain period of time the vehicle speed will increase so that from the speed of  $V_{a1}$  to  $V_{a2}$  speed. This is illustrated in mode 1 - A, namely the Electric Motor ON in the Plant, moves the Flywheel (W) wheel with a clutch condition that is not connected to the Flywheel (F).
- After having a constant speed, the Electric Motor is OFF at the plant. The system which initially received the initial torque input from the Electric Motor will be replaced by a Flywheel Torque (W; wheel) which becomes the torque input for the system

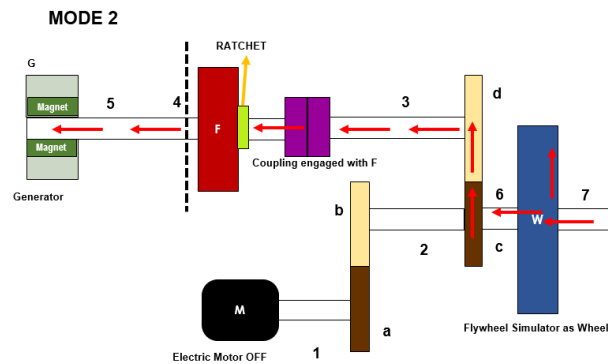

FIGURE 5. Workflow diagram of FRCS Mode 2

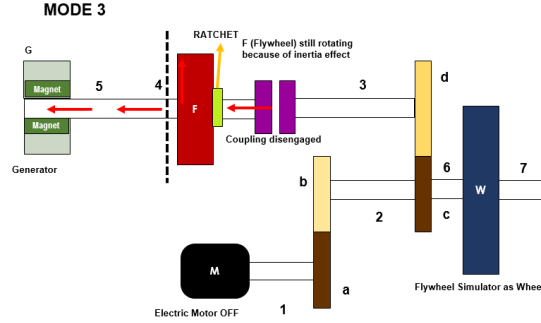

FIGURE 6. Workflow diagram of FRCS Mode 3

In mode 2 of this system, the mechanism occurred as follows :

- a) When braking on a vehicle, the brake system will be active. The electromagnetic clutch will be connected to the Flywheel (F) Plant. In this condition the electric motor is OFF (the electric motor is a representative of the gas pedal, so when braking is done, the gas pedal is lifted).

During this braking process, there is a transfer of the Flywheel (W; wheel) torque speed to the flywheel (F). With this torque transfer speed, the energy download process at the flywheel (F) is faster. In the FRCS topology equipped with a ratchet, an anti-reverse flywheel (F) will occur. The ratchet system will capture the impulse that occurs when there is braking of the vehicle as a regenerative energy input.

The forms of FRCS modeling are as follows:

1. Modeling of Electric Motors - Transmission - Flywheel (W) (Wheel Simulator)

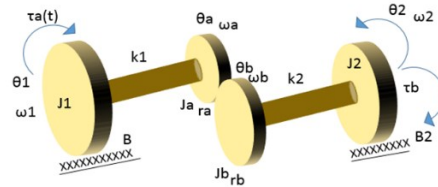
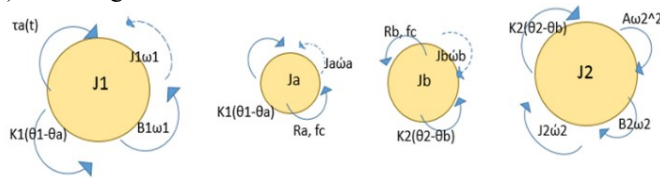

FIGURE 7. 4DOF Dynamic Modeling

Free Body Diagram (FBD) modeling is:



State Variabel :

$$\dot{\omega}_1 = \frac{1}{J_1} (-B_1\omega_1 - k_1(\theta_1 - \theta_a) + \tau_a(t))$$

$$\dot{\omega}_2 = \frac{1}{J_2} (-B_2\omega_2 - A\omega^2 - k_2(\theta_2 - \theta_b))$$

$$\dot{\omega}_a = \left[ \begin{array}{c} 1 \\ J_a + \frac{J_b}{N^2} \end{array} \right] \cdot \left[ \frac{k_2}{N} (\theta_2 - \theta_b) \right]$$

$$\dot{\theta}_1 - \dot{\theta}_a = \omega_1 - \omega_a$$

$$\dot{\theta}_2 - \dot{\theta}_b = \omega_2 - \frac{1}{N}\omega_a$$

$$\dot{\omega}a = \left[ \frac{1}{Ja + \frac{Jb}{N^2}} \cdot (k1(\theta1 - \theta a)) \right] + \left[ \frac{1}{Ja + \frac{Jb}{N^2}} \left( \frac{k2}{N} (\theta2 - \theta b) \right) \right]$$

2. Coupling modelling

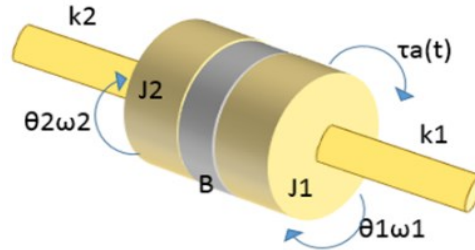
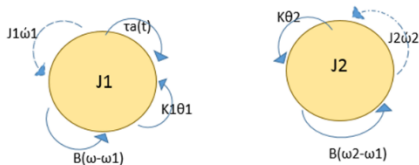

FIGURE 8. 2 DOF Dynamic Modeling

Free Body Diagram (FBD) modeling is:



State Varibel :

$$\begin{aligned} \dot{\theta}1 &= \omega1 \\ \dot{\omega}1 &= \frac{1}{J1} (-k1\theta1 - B\omega1 + B\omega2 + \tau a(t)) \\ \dot{\theta}2 &= \omega2 \\ \dot{\omega}2 &= \frac{1}{J2} (B\omega1 - k2\theta2 - B\omega2) \end{aligned}$$

Where  $\tau a = B(\omega2 - \omega1)$

3. Modeling of Flywheel (F) (Flywheel Capture) - Generator

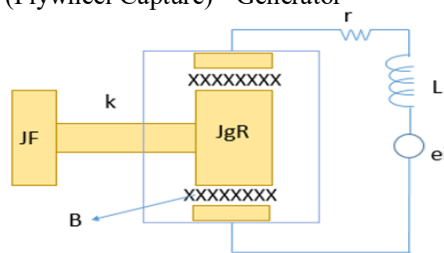

FIGURE 9. 3 DOF Dynamic Modeling

Free Body Diagram (FBD) modeling is :



State Variabel :

$$\dot{\omega}1 = \frac{1}{JF} (-k(\theta1 - \theta g) + \tau a(t))$$

$$\dot{\omega}_g = \frac{1}{J_g} (-B\omega_g + k(\theta_1 - \theta_g) + \tau e) \text{ where } \tau e = di$$

$$\frac{di}{dt} = \frac{1}{L} (-\alpha v - ri + e_i)$$

The block diagram for the system as follows

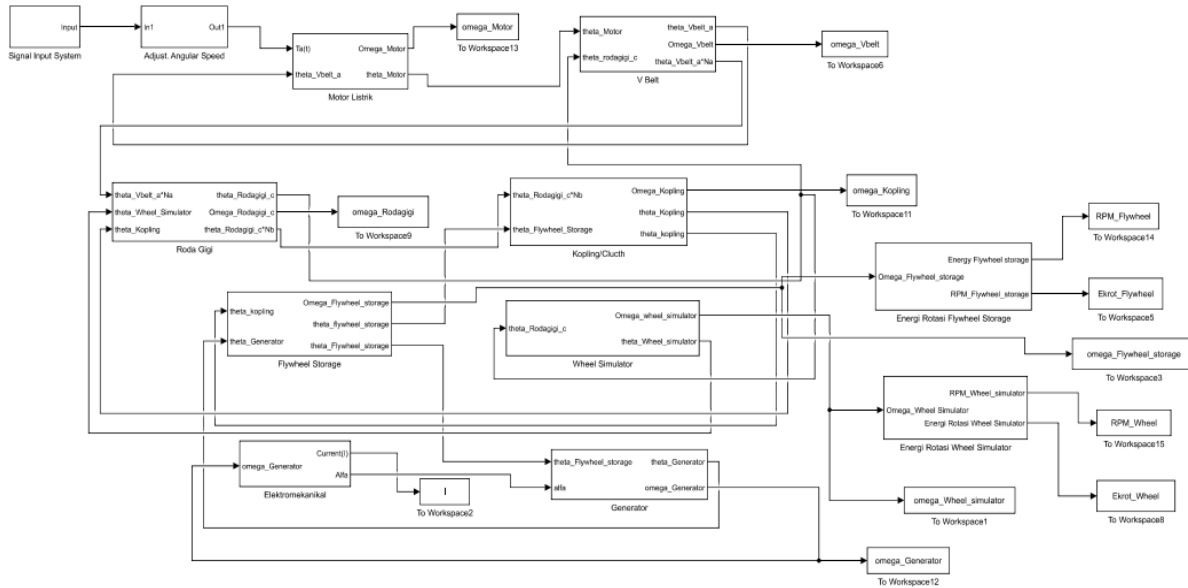

FIGURE 10. 3 block diagram of the system

The diagram of FRCS topology when operating as follows

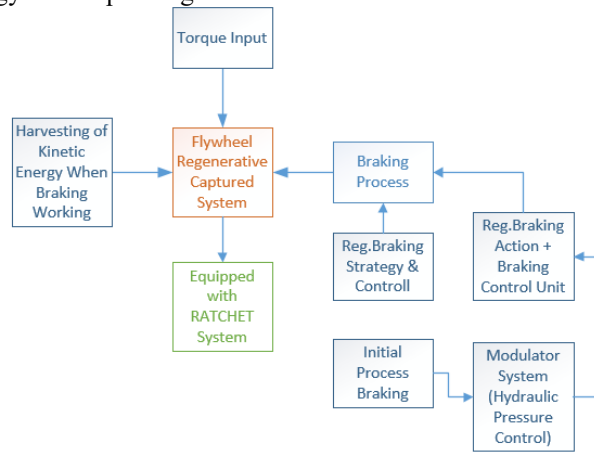
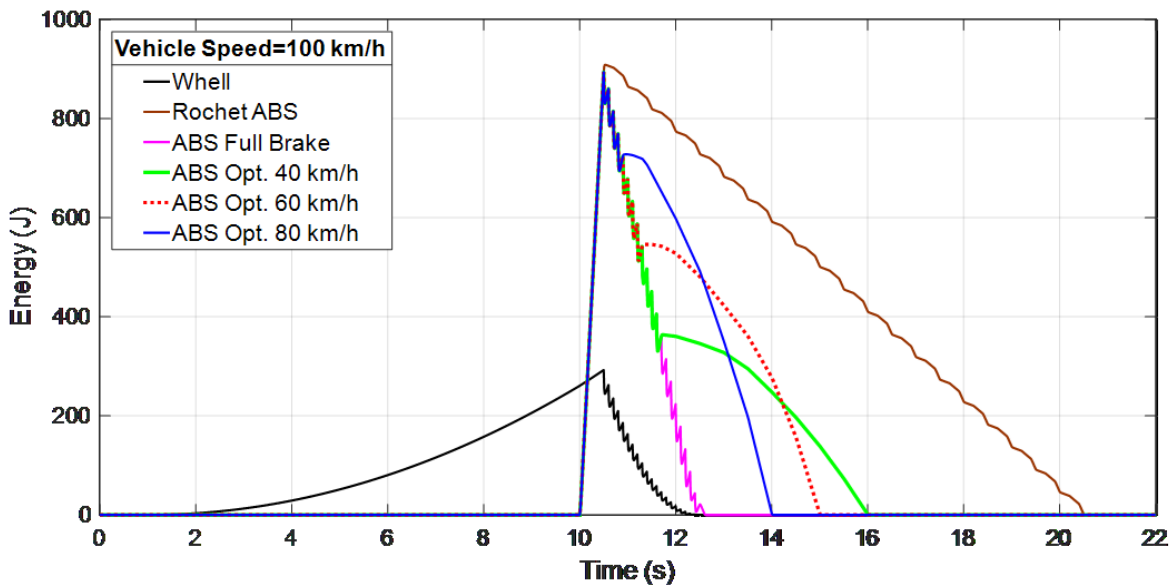
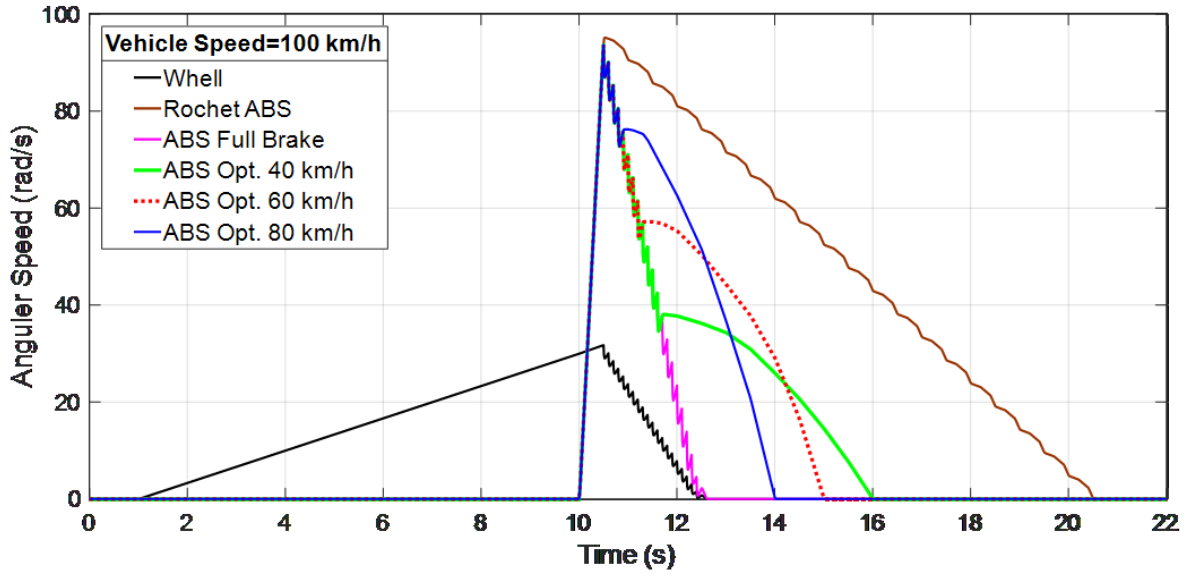

FIGURE 11. The diagram of FRCS topology





**FIGURE 12.** The angular speed optimization of Ratchet ABS and Energy captured

The variation of speed of 100 km / h obtained when full-brake without optimal release, the vehicle will stop at an interval of 2.5 seconds with a maximum angular speed of 94 rad / s. At an optimal variation of 80% the vehicle speed is obtained when the release of 80 km / h and flywheel stops with an interval of 4 seconds. At optimal 60% of vehicle speed is 60 km / h when releasing at intervals of 5 seconds, while at optimal 40% the speed is 40 km / h at an interval of 6 seconds. When compared with the use of Ratchet on the ABS Brake system, a significant result is obtained that the flywheel can spin for up to 10 seconds, so that the braking-system energy that can be downloaded will be even greater.

## CONCLUSION

In the graph, is a research on the development of ABS brake system by optimizing the percentage in deciding flywheel at a certain speed by comparing also the use of Rochet on the ABS brake system. In analyzing the graph, the researchers used the same vehicle speed variable in each condition which is 100 km / h. The speed will be made variations in terms of optimizing the release of flywheel with a percentage of 80%, 60%, 40%, and 0% (full-brake). The black colored line is a representation of the vehicle's rate of stopping, so that the vehicle can be stopped in 2.5 seconds from the start of the brake pedal is pressed

## REFERENCES

1. Hannan, M. A., Hoque, M. M., Mohamed, A., & Ayob, A. (2017). [Renewable and Sustainable Energy Reviews](https://doi.org/10.1016/j.rser.2016.11.171), 69, 771–789 (2016), <https://doi.org/10.1016/j.rser.2016.11.171>.
2. Kuo JK., & Hsieh HK., [Fuel Cells](#), 13, 1234–1241 (2013).
3. Li, L., Wang, X., Xiong, R., He, K., & Li, X., [Applied Energy](#), 183, 914–925 (2016), <https://doi.org/10.1016/j.apenergy.2016.09.031>.
4. Li, L., Li, X., Wang, X., Song, J., He, K., & Li, C., [Applied Energy](#), 176, 125–137 (2016), <https://doi.org/10.1016/j.apenergy.2016.05.042>.
5. Nian X, Peng F, Zhang H. [IEEE Trans Ind Electron](#), 61, 5798–808 (2014).
6. Ren G., Ma G., & Cong N., [Sust Energ Rev](#), 41, 225–236 (2015).
7. Zhang, J., Li, Y., Lv, C., & Yuan, Y., [Energy Conversion and Management](#), 82, 135–145 (2014), <https://doi.org/10.1016/j.enconman.2014.03.015>.