



## PAPER ACCEPTANCE NOTIFICATION

Number : 045-2/X/ICOMERA2018/LoA

Date : 2 October 2018

First Author : Subuh Isnur Haryuda

Email : subuhisnur@unesa.ac.id

Affiliation : Department of Mechanical Engineering, Universitas Negeri Surabaya

Co-authors : I Wayan Susila, Indra Herlamba Siregar, Aris Ansori

Paper Title : Power Control of Grid-Connected Photovoltaic-Wind Turbine-Buoy Conversion Energy Wave Hybrid System

Paper ID : ICOMERA\_2018\_paper\_045

Dear Sir/Madam/Dr./Prof.,

We are pleased to inform you that, after a careful double-blind peer-reviewing process, your manuscript is accepted for oral presentation at the 1st International Conference on Mechanical Engineering Research and Application 2018 (ICOMERA 2018) to be held from 23 - 25th October 2018 in Malang, Indonesia.

To be eligible to publish on IOP Conference Series (Scopus Indexed), please submit your full paper using ICOMERA 2018 paper template (<http://icomera.teknik.ub.ac.id/template/>) and make revision as advised by our reviewer.

Also, selected papers will be published in International Journal of Integrated Engineering (IJIE) – UTHM (Scopus Indexed) which is subjected to terms and conditions stipulated by IJIE editorial board. The information regarding the publication in IJIE will be informed in separate letter.

After receiving this Letter of Acceptance (LoA), you need to:

1. Submit your full paper to EasyChair by visiting our website (<http://icomera.teknik.ub.ac.id/registration-process/>).
2. Do the payment of registration fee via bank transfer (<http://icomera.teknik.ub.ac.id/registration/>) as directed in the email.
3. Send the payment confirmation by e-mail to [icomera.ub@gmail.com](mailto:icomera.ub@gmail.com) and [icomera@ub.ac.id](mailto:icomera@ub.ac.id)

Please complete the registration steps above by 19 October 2018 as the latest.

Please note that Presenter MUST be present during presentation session. Otherwise, the paper will not be published.

Should you have any questions concerning registration, conference program, and paper publication, please do not hesitate to contact us by e-mail to [icomera.ub@gmail.com](mailto:icomera.ub@gmail.com) and [icomera@ub.ac.id](mailto:icomera@ub.ac.id). For the most updated information of the conference, kindly refer to the official conference website at <http://icomera.teknik.ub.ac.id>.

Thank you,

Yours sincerely,

Agung Sugeng Widodo, ST., MT., PhD.  
Chairman of ICOMERA 2018

Korespondensi

Tanggal 8 Agustus 2018

Submission Acknowledgement "Power Control of Grid-Connected Photovoltaic-Wind Turbin-Bouy Conversion Energy Wave Hybrid System"

Eksternal

Kotak Masuk

icomera@ub.ac.id

kepada saya

Dear aris ansori:

Thank you for submitting the manuscript, "Power Control of Grid-Connected Photovoltaic-Wind Turbin-Bouy Conversion Energy Wave Hybrid System " to icomera.

Warm regards;

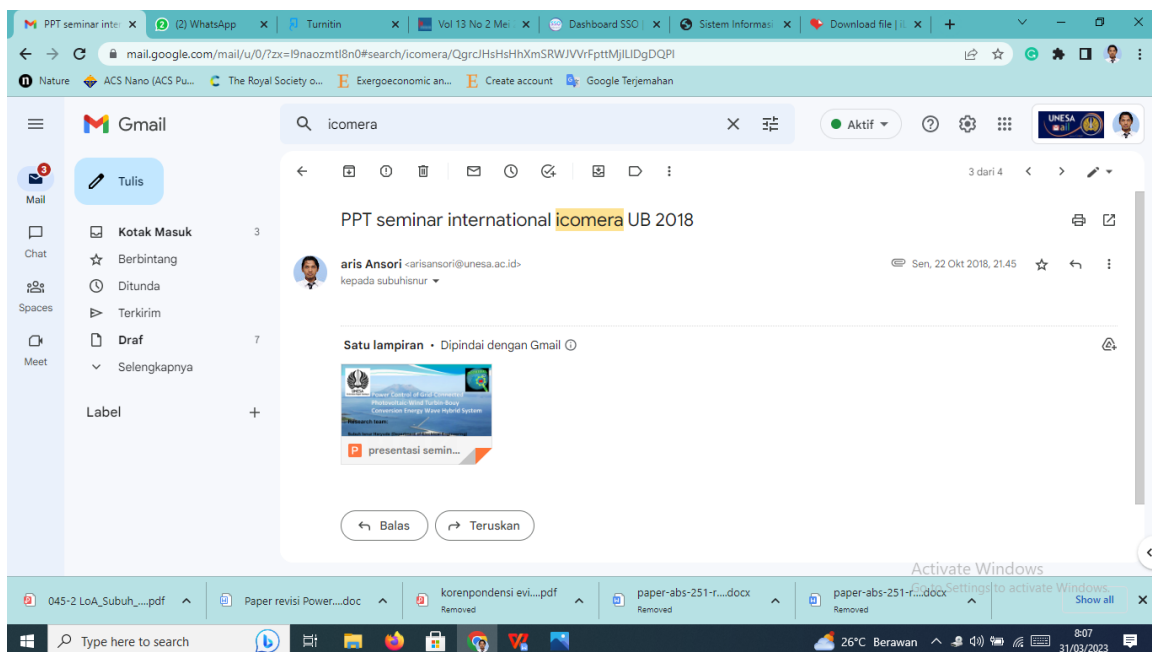

Revisi artikel tanggal 3 Desember 2018

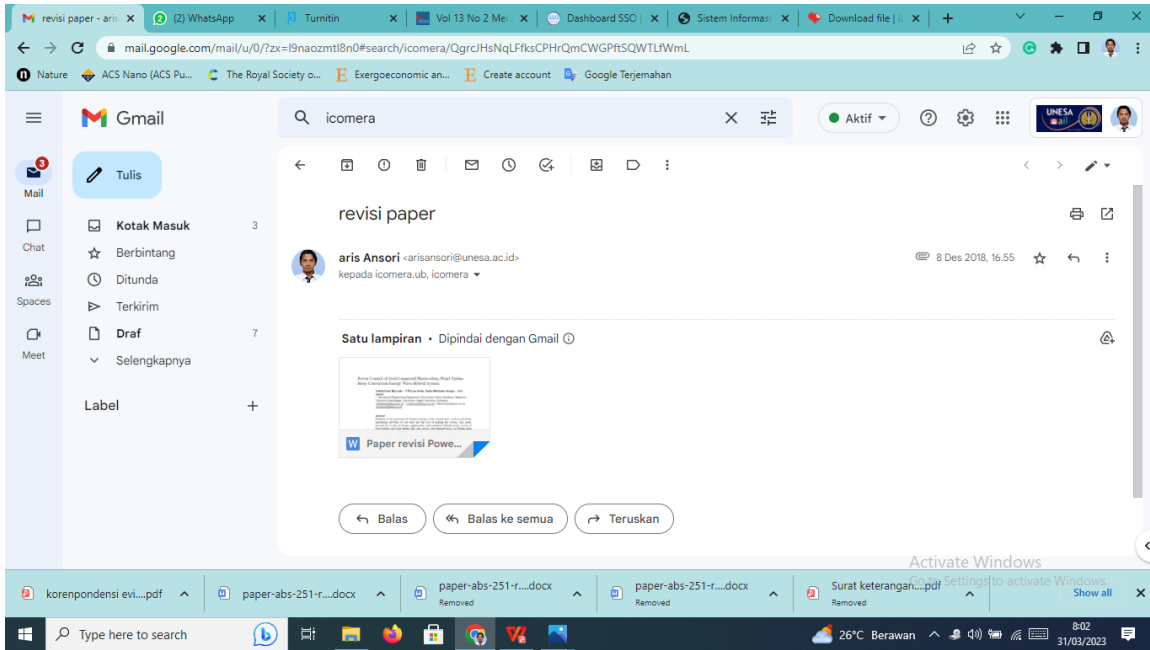

Tanggal 8 Desember 2018

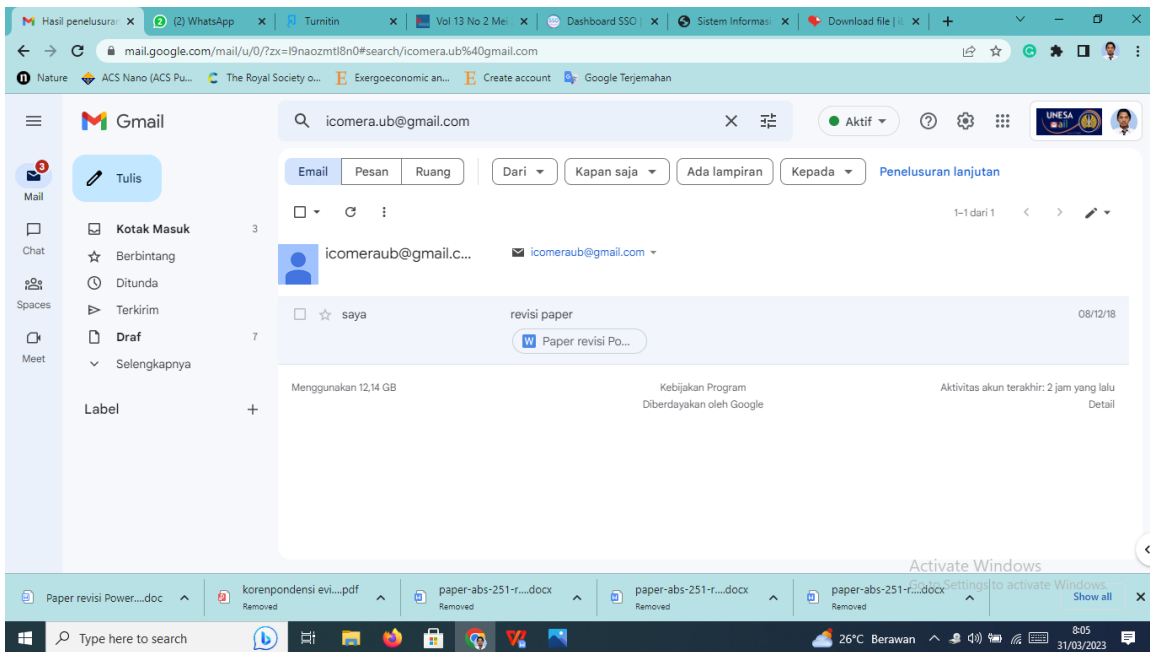

# Power Control of Grid-Connected Photovoltaic-Wind Turbin-Bouy Conversion Energy Wave Hybrid System

<sup>1</sup>Subuh Isnur Haryuda \*, <sup>2</sup>I Wayan Susila, <sup>3</sup>Indra Herlamba Siregar, <sup>4</sup> Aris Ansori

<sup>1,2,3</sup> Mechanical Engineering Department, Universitas Negeri Suarabaya, Indonesia.  
<sup>4</sup> Electrical Department, Universitas Negeri Suarabaya, Indonesia.  
<sup>1</sup>[subuhisnur@unesa.ac.id](mailto:subuhisnur@unesa.ac.id), <sup>2</sup>[wayansusila@unesa.ac.id](mailto:wayansusila@unesa.ac.id), <sup>3</sup>[indrasiregar@unesa.ac.id](mailto:indrasiregar@unesa.ac.id),  
<sup>4</sup>[arisansori@unesa.ac.id](mailto:arisansori@unesa.ac.id)

### ***Abstract***

Problems in the provision of electrical energy in the coastal areas, such as electricity installation networks do not exist and the cost of making the system. This paper presents the results of design, optimization, and control of hybrid energy system of wave energy and wind energy and solar power. The ultimate goal is to design clean energy systems to meet the demand for electrical energy on the coast. The actual power system results from two renewable power systems: (1) Grid solar power system: Solar PV / wave energy / battery / inverter system; and (2) wind turbine / wave energy / battery / inverter system. The results show that Solar PV power systems / wave energy / battery / inverter systems offer better performance. The total energy generated by the solar power system can meet the AC load for the electricity needs of the household scale with almost no power shortage. The recommended system for coastal homes is economically and environmentally friendly with excess power (0.10%) and zero noise level.

*Keywords— control, hybrid, solar PV, wind turbine, wave energy*

## **I. INTRODUCTION**

Global energy needs have increased due to population growth, housing sector growth, industrial sector. The growth of world energy consumption, such as coal, natural gas and liquid fuels reached 78% of total consumption in 2040. [1]. The use of coal energy, natural gas, liquid fuels to fuel power plants used to supply electricity needs. Whereas in 2017 coal energy consumption (57.22%), natural gas (24.82%), liquid fuel (5.81%) and new and renewable energy (EBT) (12.5%) for generating fuel electricity [2]. The use of fossil fuels as a power plant increases CO<sub>2</sub> production which has an impact on global warming and environmental pollution [3]. Solution to reduce the use of fossil fuels by using renewable energy sources for energy generation in remote areas or coastal coastal areas. Meanwhile, fulfillment of the need for electricity of around 1.2 billion people is still a problem, especially those living in remote areas, so pushing the fulfillment of electricity in remote areas continues to be driven by national or international institutions [4]. Indonesia is an archipelagic country that has a long coastline of 99,000 Km has the potential of renewable energy that has not been used optimally for energy sources of electricity generation in remote areas or in coastal areas. Meanwhile, East Java Province has no less than 79 small islands that are concentrated in the Madura Islands and a long coastline that covers the southern coast and north coast. The latest new energy potential (EBT) on the south coast can be used as an energy source for electricity generation.

The potential of renewable energy on the south coast of east Java stretches throughout the Pacitan, Tulungagung, Trenggalek, Malang, Lumajang, Jember and Bayuwangi regions. On average the latest new energy (EBT) on the coast of Malang Regency, such as wind energy with a speed of 2-6 m/s can be used as a driver of wind turbines, solar energy with an average of 4.8 Kwh/m<sup>2</sup> and wave energy with wave height around 1.5 to 2 meter that can be converted into electrical energy.

The implementation of hybrid power generation technology on the coast in Malang district as a source of electrical energy needs further research. Some obstacles to coastal renewable energy power generation, such as the continuous supply of electrical energy caused by weather and climate conditions, such as photovoltaic power plants can generate electricity during the day and the level of electricity production depends on changes in weather and climate. Meanwhile, wind turbine power plants depend on wind speed.

Power and energy management strategy for residential solar PV systems with Li-ion battery storage. Performance models for PV modules, small wind turbines, and Li-ion batteries with power smoothing applications, MAF is considered with two windows of average time of 5 and 15 minutes. In both cases, the desired smoothing effect is achieved, while the battery is worn around. 3.4 and 1.5

full cycles, each for summer and winter. Furthermore, batteries are used to maximize the use of renewable energy and minimize electricity bills, by minimizing energy purchased from utility networks. This is achieved by calculating a 15-minute average power curve for one full day, taking into account the load profile of the house and the renewable energy produced [5].

The PV / wind / diesel power plant model with the optimal configuration of the hybrid system is determined in terms of total system reliability (TED = 0%) and system costs, so that it is different from the results of optimal net present cost (TNPC), energy costs (EC), number of hours of operation, fuel consumption and the amount of CO<sub>2</sub> emitted. PV / wind / diesel / battery hybrid systems were obtained for configuration with the lowest number of wind turbines (01 wind turbines) and the highest number of photovoltaic modules (53 PV modules) due to strong solar intensity. Simulation results show that PV / wind / diesel / battery options are more economical than using PV battery systems / wind // or diesel generators only [6].

Applications for solar PV hybrid power plants, wind energy and wave energy in the coastal waters of the tamban in malang district are expected to improve the performance of renewable energy power generation systems. While the amount of electrical energy produced can be calculated from the amount of energy of each system produced.

### 1.1 Wave energy power generation

The amount of power for wave energy power plants cannot be determined with certainty. Meanwhile, the calculation of wave energy power by calculating the wave period. Calculation of wave periods is calculated by Kim Nielsen's equation.

$$T = 3,55x\sqrt{h} \quad (1)$$

with:

T = wave period (sec)

h = wave height (m)

wavelength and wave velocity can be calculated by David Ross's equation.

$$\lambda = 5,12T^2 \quad (2)$$

with:

$\lambda$  = wave length (m)

the wave velocity is calculated by the equation.

$$V = \frac{\lambda}{T} \quad (3)$$

With, v = wave speed (m/sec)

wave amplitude can be calculated by the equation

$$a = \frac{h}{2} \quad (4)$$

With, h = wave height (m)

wave kinetic energy can be calculated by the equation.

$$PE = \frac{1}{4} w.\rho.g.a^2.\lambda \text{ (joule)} \quad (5)$$

With,

a = wave amplitude (m)

w = wave width (m)

$\rho$  = density of sea water (kg/m<sup>3</sup>)

g = earth's gravity (m/s<sup>2</sup>)

meanwhile, the electrical power generated from wave energy can be calculated by the equation.

$$P_w = \frac{PE}{T} \text{ (Watt)} \quad (6)$$

While the power that can be transferred from wave energy can be calculated by the equation:

$$P = \frac{\rho g^2}{64\pi} T_e h_e \cong 0,5 T_e h_e \text{ (KW/m)} \quad (7)$$

With,

$\rho$  = density of sea water (kg/m<sup>3</sup>)

$g$  = earth's gravity (m/s<sup>2</sup>)

$T_e$  = wave period (sec)

$h_e$  = wave height (m)

The energy calculated is in the direction of wave motion with the angle  $\alpha$  between the incoming wave and its direction, the density of wave energy can be calculated by the equation:

$$P_\alpha = P \cos(\alpha) \quad (8)$$

### 1.2 Solar PV power plant

Electrical energy generated from solar energy conversion with solar PV can be calculated equation;

$$P_{\text{out}} = V_{\text{oc}} \times I_{\text{sc}} \quad (9)$$

With,

$P_{\text{out}}$  = power of photovoltaic cells (watts)

$V_{\text{oc}}$  = voltage open circuit (volts)

$I_{\text{sc}}$  = current flowing (ampere)

Solar PV efficiency is a ratio of solar energy that can be converted into electrical energy by photovoltaic cells. The amount of solar PV input energy can be calculated by measuring the amount of sunlight intensity with the solarmeter.

$$\eta = \frac{V_m I_m}{P_{\text{solar}}} = \frac{FF V_{\text{oc}} I_{\text{sc}}}{P_{\text{solar}}} \quad (10)$$

With,  $FF$  = fill factor

### 1.3 Wind turbine power plants

The principle of the conversion of wind energy to produce electricity in the power generation system is the kinetic energy of the wind to drive a wind turbine. The amount of kinetic energy ( $E_k$ ) produced is determined by the velocity of the wind flow. Kinetic energy ( $E_k$ ) wind can be calculated by the equation.

$$E_k = \frac{1}{2} m u_0^2 \quad (11)$$

With,

$m$  = mass of flowing wind (kg)

$u_0$  = wind speed (m / s)

Wind kinetic energy extracted by wind turbine blades is converted into mechanical energy. wind power that can be extracted by wind turbines from the Betz modeling, wind velocity  $u_0$  and density  $\rho$  with sweeping area of the  $A_1$  turbine rotor, can be calculated by the equation.

$$P_T = \frac{1}{2} C_p A_1 \rho u_0^3 \quad (12)$$

Wind Power is the potential energy contained in the wind whose magnitude is the result of measurements of wind speed and specific data from the blades can be calculated by the equation.

$$P_A = 0,5 \rho U_A^3 S \quad (13)$$

with,

$U_A$  = wind speed kecepatan angin (m/det)

$U_A$  = wind speed kecepatan angin (m/det)

$\rho$  = air density (kg/m<sup>3</sup>)

$S$  = Span Area (m<sup>2</sup>)

Turbine power is energy that can be absorbed by a turbine from the wind which is the result of the calculation of the measured variables such as load, height and time. turbine power can be calculated by the equation.

$$P_T = T \cdot \omega \quad (14)$$

With,

$P_T$  = power (watt)

$T$  = Braking torque (N.m)

$\omega$  = Turbine rotation (rps)

Turbine efficiency ( $C_p$ ) is the ratio of power that can be absorbed by a turbine with wind power.

$$C_p = \frac{P_T}{P_A} \quad (15)$$

Turbine density ( $\sigma$ ) is the ratio of the turbine blade area to the turbine sweep area.

$$\sigma = \frac{N \cdot c}{D} \quad (16)$$

With,

$N$  = Number of blades

$c$  = chord length (m)

$D$  = Diameter of the blade holder arm

Tip speed ratio ( $\lambda$ ) is the ratio of the speed of the rotor tip to the free wind speed. tip speed ratio will affect the rotational speed of the rotor

$$\lambda = \frac{\pi D n}{60 v} \quad (17)$$

The electrical power generated by the turbine obtained can be calculated by the equation.

$$P_e = \eta_g \eta_T \frac{1}{2} C_{p,\max} \rho A_2 v_1^3 \quad (18)$$

#### 1.4 Grid-tied solar PV-wind turbin-wave energy power system

A hybrid system model that combines solar energy sources, wind energy and wave energy. The hybrid electrical network model can use several network models, such as; 1) the generator and battery systems are installed in a separate location and connected to the AC bus before connecting to the grid (figure 1), 2). The hybrid system converts the AC to DC voltage on the generator which produces AC power (figure 2), and 3). Hybrid system with electrical system with separate connections (figure 3)

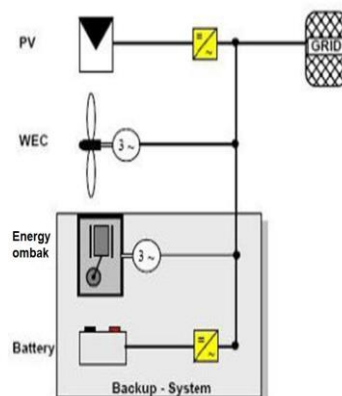

Fig. 1. The battery hybrid is installed in a location and connected to the AC bus before it is connected to the grid

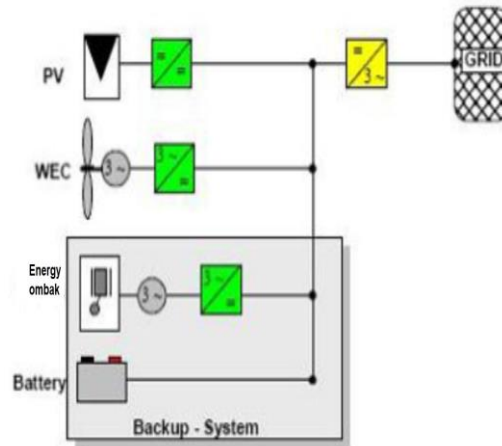

Fig. 2. Hybrid model with DC to AC voltage converter used to feed to the grid (AC)

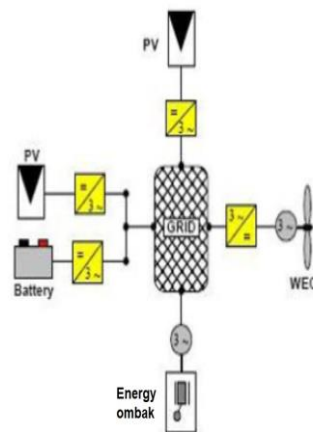

Fig. 3. Hybrid system with separate network connection between plants

This study aims to test hybrid systems of solar PV power generation, wind energy and wave energy with model 1) grid solar PV power system: Solar PV / wave energy / battery / inverter system; and (2) grid wind turbine system: wind turbine / wave energy / battery / inverter system. It should be noted that two DC-coupling sources can be realized to utilize several power supplies at the same time.

## 2. RESEARCH METHOD

We use experimental methods to determine the best way to assemble hybrid systems to improve the performance of solar PV power generation systems, wind turbines and wave energy, solar PV research instrument specifications for solar energy conversion of 100 Wp power capacity, wind turbines using H type wind turbines with the number of 6 blade blades to rotate the AC 3 phase 500 watt generator. Meanwhile, for wave energy conversion using a float model with a hydraulic system to rotate a 1 KW power 3 phase power generator.

The hybrid system model by combining power generation systems with AC power generated from wind turbines and wave conversion systems is converted into DC currents and fed to storage batteries, while channeling current to the grid in the form of AC electricity. The calculation of the electrical power produced by each generator by measuring the voltage and electric current produced, while the power that can be stored is done by measuring the battery capacity after filling the system



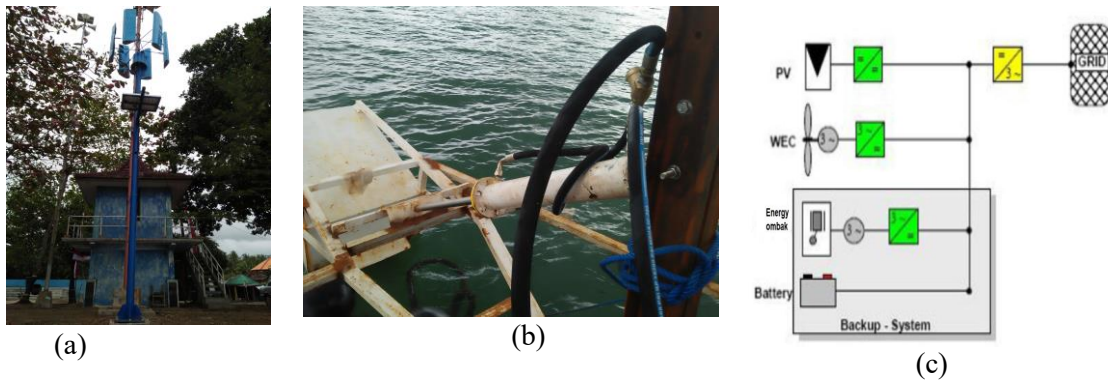

Fig. 4. Research instrument a) Solar PV-wind turbine system, b) Wave energy conversion system, (c) Hybrid electrical model

### 3. RESULTS AND ANALYSIS

The results of the measurement of the potential of solar energy, wind and wave energy in the coastal areas of Malang Regency indicate energy sources that can be used as a source of renewable energy electricity generation. The potential value of solar energy intensity is an average in the energy range (100-822 w/m<sup>2</sup>) within 06.00-16.00, wind energy potential with wind speed range (0.3-5.5 m/s) within 06.00-19.00. while the potential for wave energy with a wave height (0.40-1.5 m).

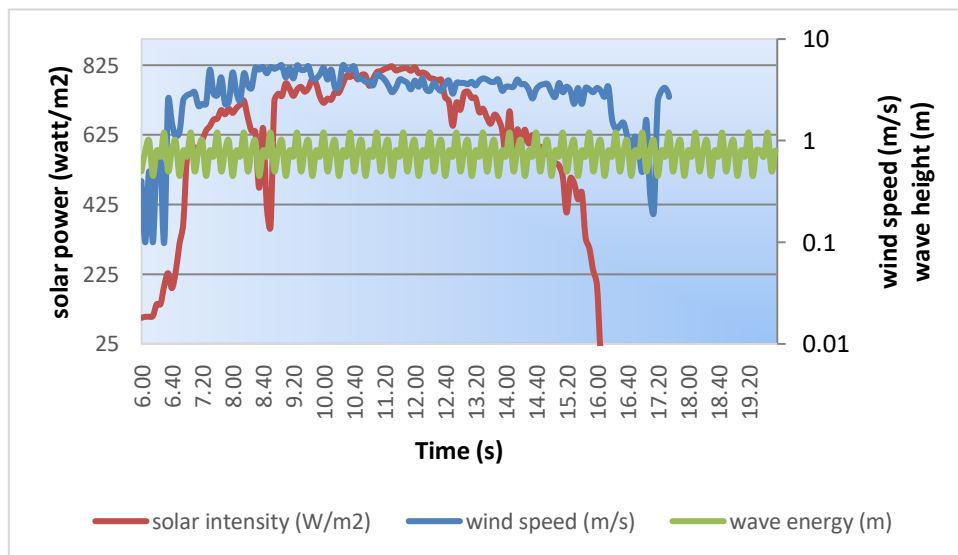

Fig. 5 Renewable energy potential in the coastal tamban

The level of stability and periodic range of energy, the source of wave energy has the same level of stability of energy. Meanwhile, solar and wind energy has very little energy stability and a short time span. Optimal use of solar energy from 06.00-16.00 with maximum energy for 3 hours at 822 w/m<sup>2</sup> at 11.00-13.00. Wind energy has a velocity range of 0.3-5.5 m / s which can rotate wind turbines well with good stability.

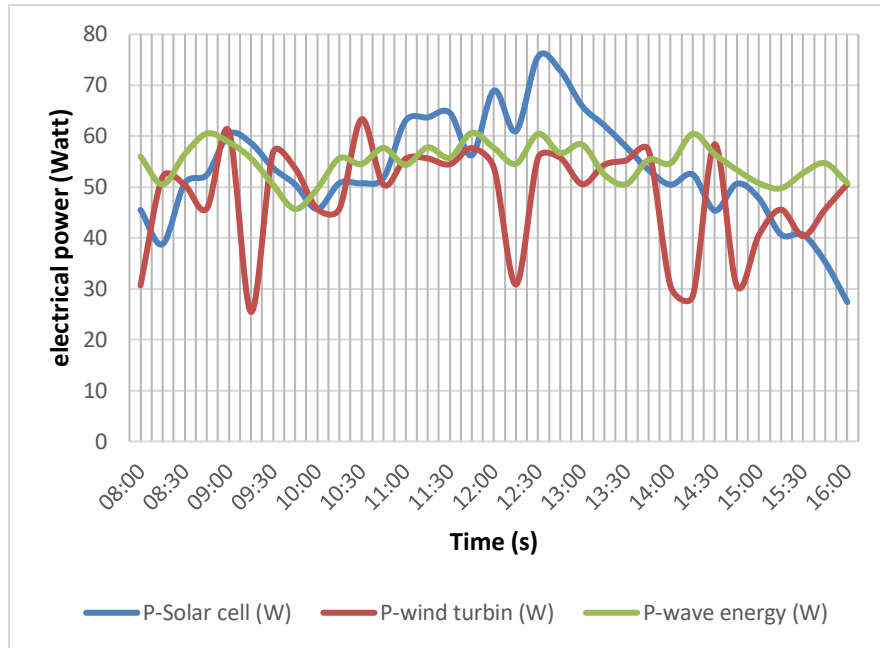

Fig. 6. Electricity produced by solar PV, wind turbines and wave energy

The conversion of solar energy, wind energy and wave energy in the coastal area of the Malang Regency basin have a fluctuating level of electrical energy production based on the supply of available energy sources. Solar PV systems have a more optimal level of electricity production than system wind turbines. The electrical energy produced by Solar PV power systems / wave energy / battery / invaders produces an average power of 3,574 KW, while the wind turbine power system / wave energy / battery / inverter system produces 3,397 KW of power. While the average electricity consumption is 3,217 KW. The model of conversion system of coastal renewable energy Solar PV power systems / wave energy / battery / inverter is more performace in the production of electricity compared to wind turbine / wave energy / battery / inverter with excess power (0.10%) and noise free. The system of Solar PV power systems / wave energy / battery / inverter economically, and performance can be recommended implemented as a power plant in coastal areas.

#### 4. CONCLUSION

Hybrid power plants with renewable energy sources of solar energy, wind energy and wave energy in coastal areas of the Malang district can be utilized to supply the electricity needs of the coastal communities. Solar PV systems have a more optimal level of electricity production than system wind turbines. Meanwhile, the incorporation of wave energy hybrid systems in solar PV systems and wind turbines results in the stability of different electrical energy production. Solar PV power systems / wave energy / battery / inverter generate an average power of 3.574 KW, while the wind turbine / wave energy / battery / inverter system model produces 3,397 KW of power. Models of Solar PV power systems / wave energy / battery / inverter are more performace in the production of electrical energy compared to wind turbine / wave energy / battery / inverter systems with excess power (0.10%) and noise-free.

#### 5. Acknowledgments

This research was supported by the national research incentive research program, funded by the Ministry of Research, Technology and Higher Education (No. 000005 / UN38.11-P / LT / 2018).

#### 6. REFERENCES

- [1] U.S. Energy Information Administration. International Energy Outlook 2018; Available602 from: <http://www.eia.gov/forecasts/ieo/world.cfm> (accessed 13.8.2018)

- [2] Kementrian Energi dan Sumber Daya Mineral (ESDM); from: <http://bisnis.com/amp/read/20180304/44/745790/pembangkit-listrik-bauran-batu-bara-57> (accessed 15.8.2018).
- [3] Wu Z, Xia X. Optimal switching renewable energy system for demand side management. *Solar Energy* 2015; 114: 278-288
- [4] Tazvinga H, Xia X, Zhang J. Minimum cost solution of photovoltaic-diesel-battery hybrid power systems for remote consumers. *Solar Energy* 2013; 96: 292-299.
- [5] B.N.PrashanthR, PramodG.B, VeereshKumar. Design and Development of Hybrid Wind and Solar Energy System for Power Generation Materials today proceeding; Volume 5, Issue 5, Part 2, 2018, Pages 11415-11422
- [6] Abdelhamid Kaabeche a, Rachid Ibtouen. Techno-economic optimization of hybrid photovoltaic/wind/diesel/ battery generation in a stand-alone power system. *Solar Energy*. 2014; 103 171–182
- [7] Hong Y, Lian R. Optimal sizing of hybrid wind/PV/diesel generation in a stand-alone power system using Markov-based genetic algorithm. *IEEE Transactions on Power Delivery* 2012;611 27(2):640-647

